

FORMTRACER CS-3200

COMBINED CONTOUR AND SURFACE MEASUREMENT
MACHINE DELIVERS HIGH ACCURACY, HIGH SPEED AND
SIMPLIFIED CNC MEASUREMENT.

FORM MEASUREMENT



A rich choice of functions to enhance your measurement efficiency

Featuring a wide measuring range and high-resolution detector, many kinds of measurement from contours to surface roughness are covered. Single-unit measurement reduces setup labor and measurement time.

Wide measuring range and high-resolution detector

Measuring range (Z-axis): 5 mm (80 nm resolution) to 0.05 mm (0.8 nm resolution)

Accuracy (Z-axis): $\pm(1.5+2H/100)$ μm , H = Height from horizontal plane (mm)

Enhanced
measurement
efficiency

Spacesaving

Resourcesaving



Conventional measurements...

STEP 1 Contour measurement STEP 2 Surface roughness measurement



with CS-3200

Surface roughness measurement involves setting up the machine again with a different detector.

Enhanced measurement efficiency



Single setup and single tracing - no detector change

Conventional measurement rooms needed...

Contour measuring instrument



Surface roughness measuring instrument



with CS-3200

Space for 2 measuring instruments, in addition to 2 PCs and 2 printers.

Spacesaving



Space for just a single measuring instrument

Conventional printed results...

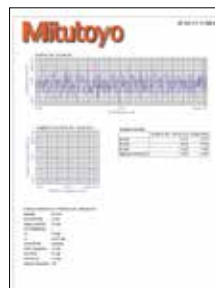
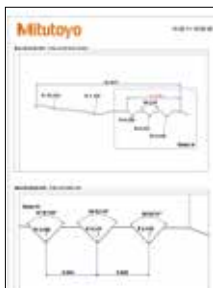

with CS-3200

Contour measuring instrument and surface roughness measuring instrument print measurement data individually.

Resource-saving

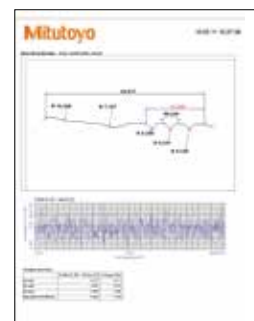

One inspection certificate printed with a minimum amount of paper, using a single printer and reducing energy requirements

Formtracer CS-3200

Highly accurate linear encoders on X/Z2-axis

The drive unit (X-axis) and column (Z2-axis) are equipped with high-accuracy linear scales (ABS type) enabling fully automatic measurement combining vertical and horizontal movement.

This improves reproducibility of continuous automatic measurement of small holes in the vertical direction and repeated measurement of parts which are difficult to position.

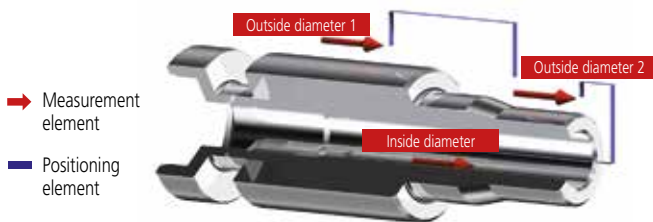

Continuous measurement example
(Outside diameter 1 → Outside diameter 2 → Inside diameter)

Improved measurement efficiency

Dramatically increased drive speed (X-axis: 80 mm/s, Z2-axis: 20 mm/s) further reduces total measurement time. Small holes can be efficiently measured using the fine-feed knobs on the X- and Z2-axes.



Small hole measurement example



Y- and Z-axis positioning using column (Z2-axis) fine-feed knob or cross-travel table (optional)



Measurement start positioning by (X-axis) fine-feed knob

Sophisticated design

The detector unit can be extended to avoid interference between the drive unit and workpiece.

All detector and drive unit cables are housed inside the main unit to eliminate any risk of abrasion and guarantee trouble free, high-speed operation.



Optional detector for wider measurement range

Measuring range in Z1-axis (height) direction is dramatically increased from 5mm to 50mm when a contour detector unit 3200*1, *2 is mounted. (Both are factory-set options.)



*1: Stylus for CS-3200 cannot be used. Stylus for contour measuring instruments CV-3200 series can be used. Refer to the Contour Measuring Systems CONTRACER CV-3200/4500 series (Catalog No. GB-20003) for specifications, etc.

*2: Supports contour measurement only.

Drive unit tilting function and air vibration-damping stand are standard features.

Drive unit (X-axis) tilting function powerfully supports measurements on inclined planes and for heavy workpieces that are not easily moved.



Software FORMTRACEPAK

MiCAT

Mitutoyo Intelligent Computer Aided Technology

the standard in world metrology software

FORM

FORMTRACEPAK provides a wide range of support, including measuring instrument control, contour analysis, surface roughness analysis, design data creation, contour verification, and inspection certificate creation functions!

Various functions are available to meet the needs of every department, including simplified repetitive measurements conducted by inspection departments and thorough pursuit of surface texture enhancement by R&D departments.



Measuring instrument control

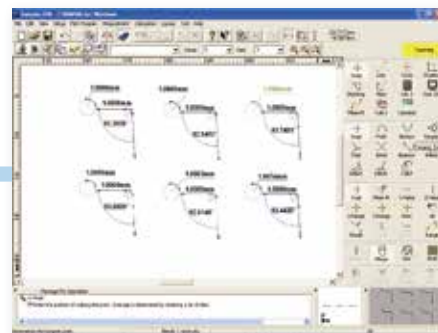

Contour analysis

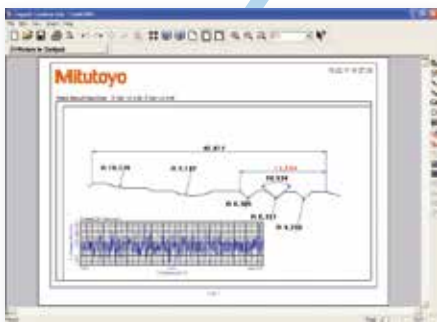

Inspection certificate creation

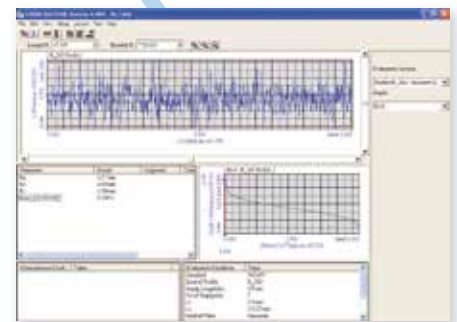

Surface roughness analysis



Contour verification

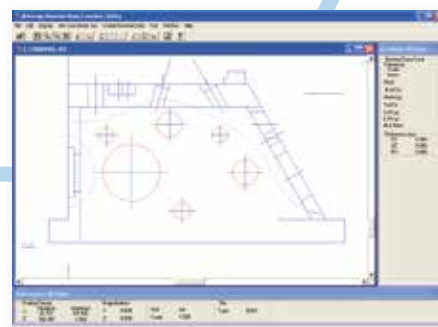

Design data creation (CAD file import)

Software FORMTRACEPAK

Measurement control

- All the command icons necessary for executing or creating a measurement procedure (part program) are laid out on the measurement control screen. Any unused icon and display area can be displayed or hidden arbitrarily, allowing the operator to customize the screen layout for ease of use.
- A measurement procedure can be easily invoked by selecting it from the pull-down menu.



Contour analysis function

- Various commands including point (10 kinds), line (6 kinds), and circle (6 kinds) are provided to cover the basic elements of analysis. Standard calculation commands that combine these elements for angle, pitch or distance calculation are also provided. The display can be tailored by the customization function to suit the application. For example, the calculation command can be hidden to simplify the measurement environment.
- The Outlier Removal Function is very useful, for example, to automatically remove irregular flaws from the data and set the calculation range for sections where the boundary between a circle and a line cannot be easily identified.
- Calculation results are output as text (in csv or/and txt format). Geometrical measurement data can be either output as point-series data into a text file or CAD file (in DXF or IGES format) or copied onto the clipboard. It is also possible to use some commercial documentation software and statistical processing software to share the data on a PC that is not installed with the Mitutoyo-original analysis software, or where reverse engineering with CAD is intended.

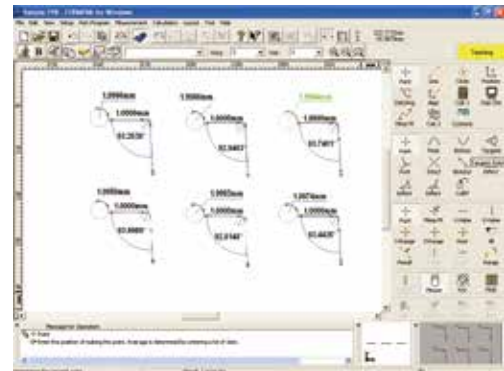

Surface roughness analysis function

- Analysis conforming to global roughness standards: EN ISO, JIS ('82, '94, '01), ANSI and VDA, etc.
- In addition to parameter calculation, various graph analysis functions are available. Can be widely used for daily quality control, in addition to use in R&D departments.
- There are also various data correction (inclination, curved surface) and deletion functions provided.

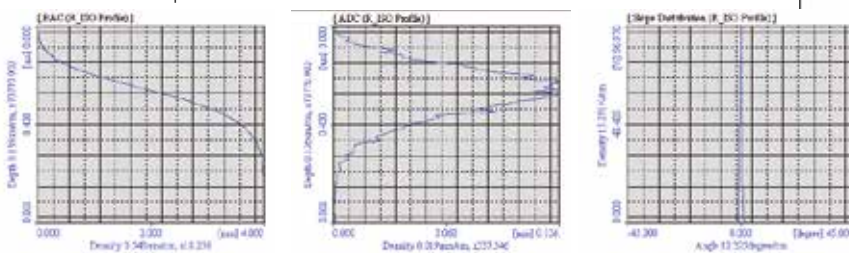
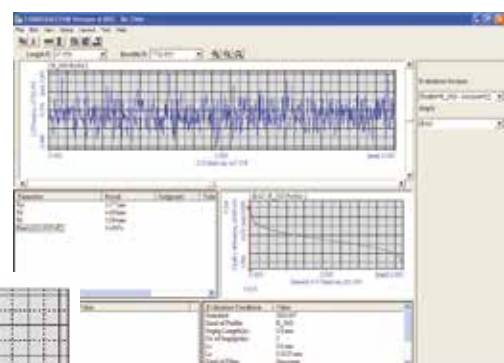

Optional accessories for automatic measurement

Y-axis table: No. 178-097

Enables efficient, automatic measurement of multiple aligned workpieces and multiple points on a single measurement surface.



Travel range	200mm
Resolution	0.05μm
Positioning accuracy	±3μm
Drive speed	Max 80mm/s
Maximum load	50kg
Mass	28kg



Rotary table / θ1-axis table: No. 12AAD975

For efficient measurement in the axial/transverse directions. When measuring a cylindrical workpiece, automatic alignment can be performed in combination with the Y-axis table. (θ1-axis mounting plate (12AAE630) is required when directly installing on the base of the CS-3200.)

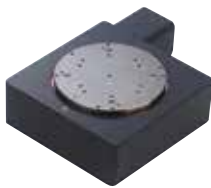

Displacement	360°
Resolution	0.004°
Maximum load	12kg
Rotational speed	Max10°/s
Mass	7kg



Rotary table / θ2-axis unit: No. 178-078

You can measure multiple points on a cylindrical workpiece and automate front/rear-side measurement. (θ2-axis mounting plate (12AAE718) is required when directly installing on the base of the CS-3200.)



Displacement	360°
Resolution	0.0072°
Maximum load (loading moment)	4kg (343 Nc·m or less)
Rotational speed	Max18°/s
Mass	5kg



Quick chuck: No. 211-032

This chuck is useful when measuring small workpieces. You can easily clamp them with its knurled ring.



Retention range	Inner latch: OD ø1 to ø36 mm Inner latch: ID ø16 to ø69 mm Outer latch: OD ø25 to ø79 mm
Dimensions (D x H)	ø118 x 41 mm
Mass	1.2 kg

Micro-chuck: No. 211-031

This chuck is suitable for clamping extra-small diameter workpieces (ø1 mm or less), which cannot be retained with the Quick Chuck.



Retention range	OD ø0 to ø1.5 mm
Dimensions (D x H)	ø107 x 48.5 mm
Mass	0.6kg

Auto-leveling table: No. 178-087

This is a platform that performs fully automatic leveling as measurement starts, freeing the user from this troublesome operation. Fully automatic leveling can be done quickly by anyone. In addition, the operation is easy and reliable.



Inclination adjustment angle	±2°
Maximum load	7kg
Table dimensions	130 x 112 mm
Mass	4 kg

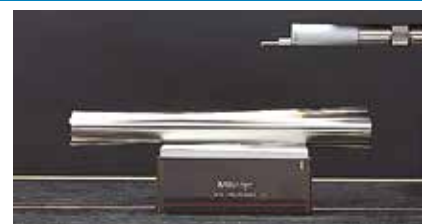

Optional accessories for expanding the application range

3-axis adjustment table : No. 178-047

This table helps make the alignment adjustments required when measuring cylindrical surfaces. The corrections for the pitch angle and the swivel angle are determined from a preliminary measurement and the Digimatic micrometers are adjusted accordingly. A flat-surfaced workpiece can also be leveled with this table.



Inclination adjustment angle	±1.5°
Swiveling angle	±2°
Y-axis travel range	±12.5 mm
Resolution	0.001mm
Table dimensions	130x100mm
Maximum load	15kg

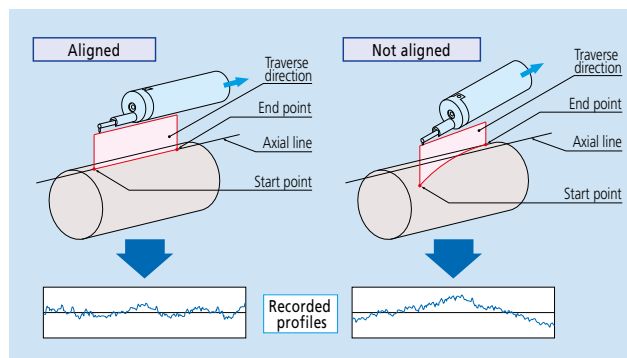

Others



Possible styli with the FORMTRACER model CS-3200

Styli for surface and contour measurement

Type	Dimensions	Specifications
Standard stylus (No. 12AAD554) Standard accessory		<ul style="list-style-type: none"> • Radius of tip curvature: 2 μm • Tip form: 60° cone • Tip material: Diamond • For contour/surface roughness measurement • Measurable depth: 7 mm max.
Cone stylus (No. 12AAD552) Standard accessory		<ul style="list-style-type: none"> • Radius of tip curvature: 25 μm • Tip form: 30° cone • Tip material: Sapphire • For contour measurement • Measurable depth: 7 mm max.
Small hole stylus (No. 12AAD556)		<ul style="list-style-type: none"> • Radius of tip curvature: 2 μm • Tip form: 60° cone • Tip material: Diamond • For contour/surface roughness measurement • Applicable hole: ø 2 mm min. • Measurable depth: 15 mm max.
Eccentric type stylus (No. 12AAD558)		<ul style="list-style-type: none"> • Radius of tip curvature: 2 μm • Tip form: 60° cone • Tip material: Diamond • For contour/surface roughness measurement • Offset from center line: 15 mm
Deep groove stylus (No. 12AAD560)		<ul style="list-style-type: none"> • Radius of tip curvature: 2 μm • Tip form: 60° cone • Tip material: Diamond • For contour/surface roughness measurement • Measurable depth: 20 mm max.
2x-long stylus*1 (No. 12AAD562)		<ul style="list-style-type: none"> • Radius of tip curvature: 5 μm • Tip form: 40° cone • Tip material: Diamond • For contour/surface roughness measurement

*1: Measuring force is 4mN and the Z1 measuring range and resolution is double that of the standard stylus.

* Styli shown on this page are for the CS-3200 standard detector unit. Cannot be used with contour detector units 3200/4500 (factory-set options).

Styli for contour measuring instrument CV-3200/4500 series can be used with contour detector unit 3200/4500.

Technical information

Model No.		FORMTRACER CS-3200S4
Order No. (main unit)**		525-401D
Measuring range	X-axis	100 mm
	Z1-axis (detector unit)*	5 mm
Z2-axis (column) travel		300 mm
X-axis traverse linearity (in horizontal orientation)		0.2 μ m / 100 mm (0.4 μ m / 100 mm: at the extended detector position)
Indication accuracy	X-axis	$\pm(0.8+0.01L)$ μ m L = Drive length (mm)
	Z1-axis (detector unit)	$\pm(1.5+I2HI/100)$ μ m, H = Measurement height from the horizontal position (mm)
Resolution	X-axis	0.05 μ m
	Z1-axis (detector unit)*	80 nm [5 mm range], 8 nm [0.5 mm range], 0.8 nm [0.05 mm range]
	Z2-axis (column)	1 μ m
Drive speed	X-axis	0 - 80 mm/s and manual
	Z2-axis (column)	0 - 20 mm/s and manual
Measuring speed	In surface roughness measurement	0.02, 0.05, 0.1, 0.2 mm/s
	In contour measurement	0.02, 0.05, 0.1, 0.2, 0.5, 1, 2 mm/s
X-axis inclining range		$\pm 45^\circ$
Measuring direction		Forward/backward
Face of stylus		Downward
Traceable angle		$\pm 65^\circ$ (using the standard chisel-cut stylus and depending on the surface roughness)
Measuring force*		0.75 mN
Stylus tip	Standard stylus	Tip angle: 60°, Tip radius: 2 μ m, Diamond tip (for contour and surface roughness measurement)
	Cone stylus	Tip angle: 30°, Tip radius: 25 μ m, Sapphire tip (for contour measurement)
Base size (W x D)		600 x 450 mm
External dimensions (W x D x H)	Main unit	756 x 482 x 966 mm
	Vibration isolating stand	810 x 755 x 700 mm
	Controller unit	221 x 344 x 490 mm
	Remote control box	248 x 102 x 62.2 mm
Mass	Main unit	140 kg
	Vibration isolating stand	150 kg
	Controller unit	14 kg
	Remote control box	0.9 kg
Air source (for vibration isolating stand)	Air pressure	390 kPa
	Air consumption	30L/day to 50L/day in standard condition

* When using 2x-long stylus (12AAD562)
 Z1-axis (detector unit) measuring range: 10 mm
 Z1-axis (detector unit) resolution / range: 160 nm / 10 mm, 16 nm / 1 mm, 1.6 nm / 0.1 mm
 Measuring force: 4 mN

** Suffix number for your AC power cable standard
 To denote your AC power cable standard add the following suffixes to the order No., e.g. 525-401A
A for UL/CSA & RoHS, **C** for PSE & RoHS (mm model only), **D** for CEE & RoHS, **E** for BS & RoHS, **DC** for CCC & RoHS, **K** for EK & RoHS (mm model only)

Main Unit Startup System

This machine incorporates a startup system (relocation detection system), which disables operation when an unexpected vibration is applied or the machine is relocated. Be sure to contact your nearest Mitutoyo prior to relocating this machine after initial installation.

Dimensions

Main unit

Unit: mm

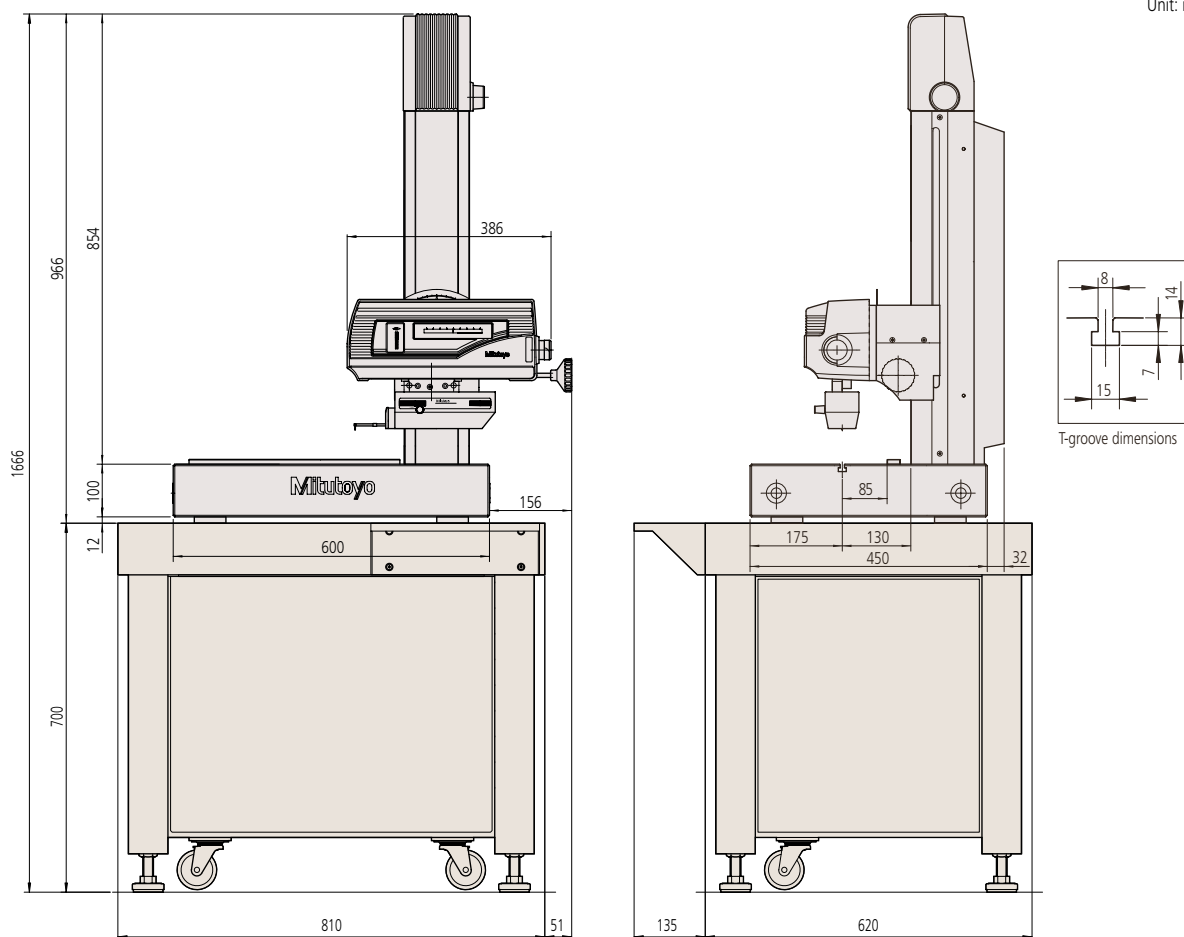

Measurement range

Normal detector position

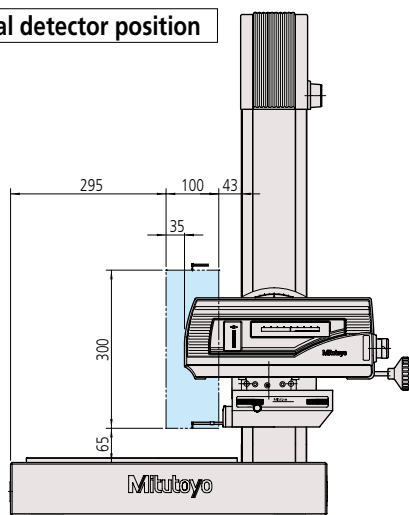

When detector is maximally extended
(Extended by 70 mm from normal position)

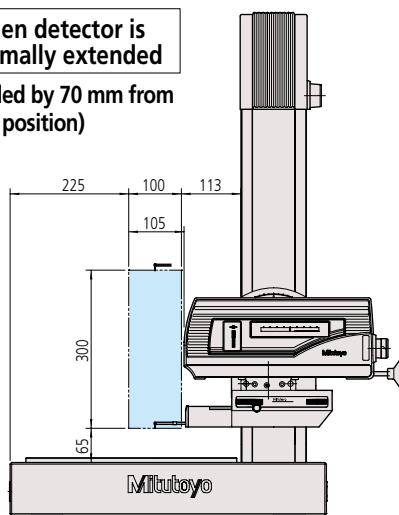

* The detector unit can be clamped at any position between normal and the maximally extended position.
* Consult Mitutoyo for the measurement range of contour detector units 3000/4000 (factory-set options).

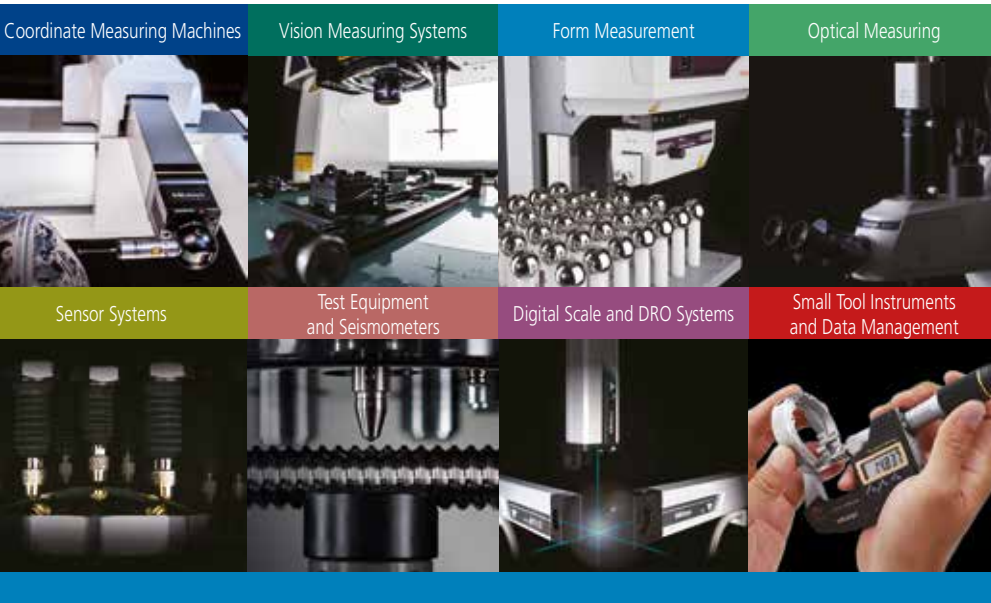

**Whatever your challenges are,
Mitutoyo supports you from start to finish.**

Mitutoyo is not only a manufacturer of top quality measuring products but one that also offers qualified support for the lifetime of the equipment, backed up by comprehensive services that ensure your staff can make the very best use of the investment.

Apart from the basics of calibration and repair, Mitutoyo offers product and metrology training, as well as IT support for the sophisticated software used in modern measuring technology. We can also design, build, test and deliver bespoke measuring solutions and even, if deemed cost-effective, take your critical measurement challenges in-house on a sub-contract basis.

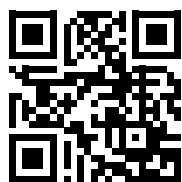

**Find additional product literature
and our product catalogue**

www.mitutoyo.eu

Note: Product illustrations are without obligation. Product descriptions respectively capability characteristics are only binding when explicitly agreed upon. MITUTOYO and MiCAT are either registered trademarks or trademarks of Mitutoyo Corp. in Japan and/or other countries/regions. MeasurLink is a registered trademark or trademark of Mitutoyo America Corp. in the United States and/or other countries. Other product, company and brand names mentioned herein are for identification purposes only and may be the trademarks of their respective holders.

Mitutoyo

Mitutoyo Europe GmbH

Borsigstraße 8-10
41469 Neuss

Tel. +49 (0) 2137-102-0

Fax +49 (0) 2137-102-351

info@mitutoyo.eu

www.mitutoyo.eu